

**OLLSCOIL NA hÉIREANN, GAILLIMH**  
NATIONAL UNIVERSITY OF IRELAND, GALWAY

**AUTUMN EXAMINATIONS 2001**

**THIRD YEAR ELECTRONIC AND COMPUTER ENGINEERING**

EE321 ANALOGUE SYSTEMS DESIGN II

Professor L.E. Davis  
Professor D.J. Wilcox  
Mr. J. Breslin

Duration of Examination: **TWO** hours  
Instructions: Answer **THREE** questions

1.

(a)

Write a short description for each of the following types of diode. [3 x 3 marks]

- Schottky diode
- Varactor diode
- LED

(b)

A Zener diode circuit for voltage regulation is given in Fig. 1.

- (i) Sketch the  $i_D$  vs.  $v_D$  characteristic for a Zener diode showing the various regions of operation. [2 marks]
- (ii) In which region does the Zener diode operate for the voltage regulator application shown? [1 mark]
- (iii) For varying source voltage and load current, analyse the circuit in Fig. 1 to determine the proper range of values for  $R_i$  that will allow the diode to maintain a constant output voltage (by keeping the Zener current between its minimum and maximum values). [6 marks]
- (iv) Define percentage regulation for the Zener diode voltage regulator. [2 marks]

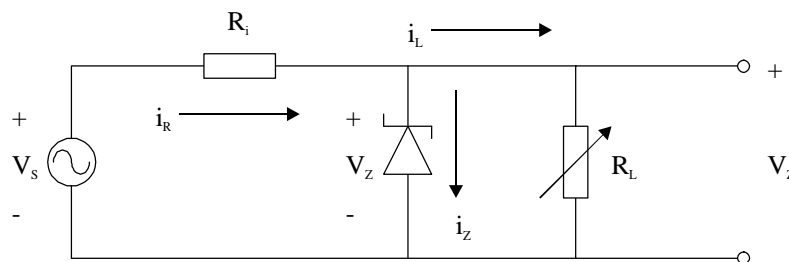

Fig. 1

[cont'd]

2.

(a)

- (i) Describe the properties of an *ideal diode*. [2 marks]
- (ii) What is the name of the circuit in Fig. 2, and what is its purpose? [1 mark]
- (iii) For a sinusoidal input waveform  $V_s$  with a peak-to-peak voltage of 5 V, sketch the output waveform  $V_o$  if the characteristic curve of the real diode is as shown in Fig. 3. [4 marks]

(b)

- (i) Describe the effect on  $V_o$  of placing a capacitor  $C$  between points A and B in the circuit shown in Fig. 2, i.e. in parallel with the load. [4 marks]
- (ii) Give an expression for the percentage ripple on the output signal  $V_o$  when the capacitor is included in the circuit. [4 marks]
- (iii) Calculate the percentage ripple if the circuit parameters are as follows: the period of the input sinusoidal waveform is 16.7 ms, the input peak-to-peak voltage is 5 V, the load resistance is  $100 \Omega$ , and the capacitor value is  $1000 \mu\text{F}$ . What would happen if the capacitor value  $C$  was increased? [5 marks]

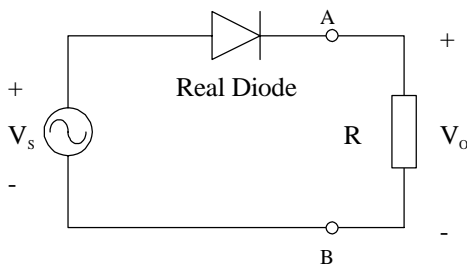

Fig. 2

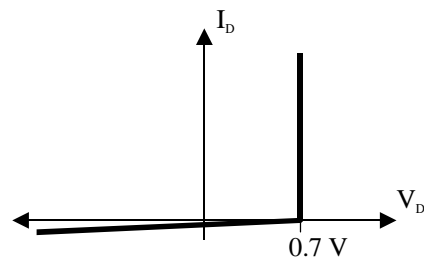

Fig. 3

3.

- (a) What is meant by the term *common base*? [1 mark]
- (b) Perform a DC analysis of the base biasing section of the *common emitter* amplifier as shown in Fig. 4, and hence derive formulæ for the position of the DC operating point. [8 marks]
- (c) Calculate the DC operating point for this common emitter amplifier circuit with the component values given in Table 1. [6 marks]
- (d) Find the value of  $I_B$ , i.e. the  $i_B$  characteristic on which the DC operating point lies. [2 marks]
- (e) What is the equation of the DC load line for this common emitter amplifier circuit? [3 marks]

|                                |                             |
|--------------------------------|-----------------------------|
| $V_{CC} = 30 \text{ V}$        | $R_E = 2.2 \text{ k}\Omega$ |
| $R_{B1} = 33 \text{ k}\Omega$  | $R_C = 10 \text{ k}\Omega$  |
| $R_{B2} = 4.7 \text{ k}\Omega$ | BJT $\beta = 75$            |

Table 1

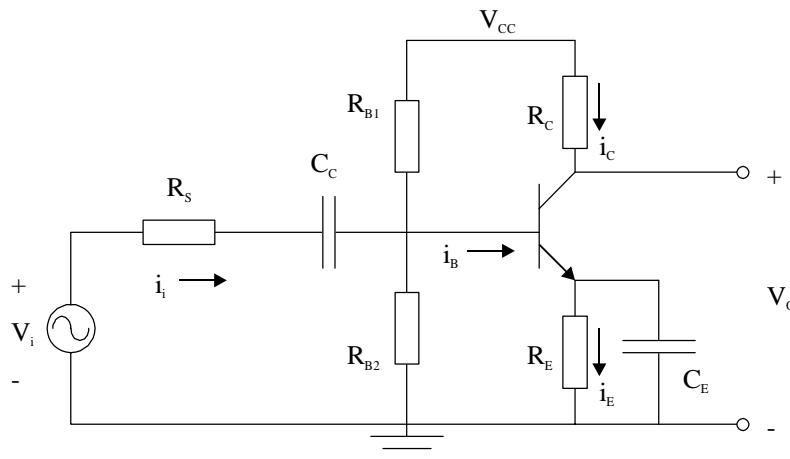

Fig. 4

[cont'd]

4.

- (a) Draw the electrical circuit symbol for a Junction Field Effect Transistor (JFET), labelling the terminals and showing the relevant currents and voltages. **[3 marks]**
- (b) Describe the main properties of an n-channel JFET. **[6 marks]**
- (c) Why are two voltage supplies required for a JFET to operate? **[1 mark]**
- (d) Sketch the states of JFET operation on an  $i_{DS}$  vs.  $v_{DS}$  characteristic curve. **[2 marks]**
- (e) Give equations for (i) the voltage at which JFET pinch-off begins and (ii) the current in the pinch-off region. **[4 marks]**
- (f) Sketch the  $i_{DS}$  vs.  $v_{DS}$  JFET characteristic curves for  $v_{GS} = 0, -1, -2$  and  $-2.5$  V with the specifications given below. **[4 marks]**
  - $I_{DSS} = 20$  mA
  - $V_{GSCO} = -3$  V

5.

- (a) Explain the operation of an integrator using the following points in your explanation:
  - (i) Circuit diagram. **[2 marks]**
  - (ii) Derive an expression for  $v_o$ . **[6 marks]**
  - (iii) Sketch the  $v_o$  you would expect for a square wave input (your diagram should include both input and output waveforms). **[4 marks]**
- (b) Explain briefly what is meant by the following specifications in practical operational amplifier circuits (suggest typical values where appropriate).
  - (i) Input offset voltage. **[2 marks]**
  - (ii) Slew rate. **[2 marks]**
- (c) Calculate the input offset voltage for the circuit in Fig. 5 given  $V_o = -8$  V. **[4 marks]**

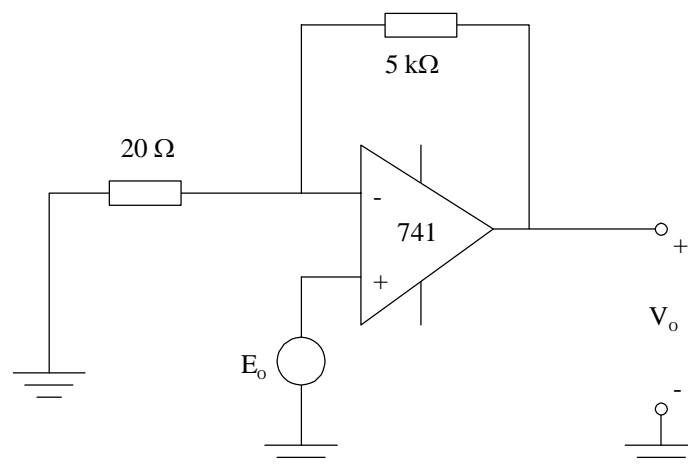

Fig. 5